

## SK12-12 12V - 12AH

The rechargeable batteries are lead-lead dioxide systems. The dilute sulfuric acid electrolyte is absorbed by separators and plates and thus immobilized. Should the battery be accidentally overcharged producing hydrogen and oxygen, special one-way valves allow the gases to escape thus avoiding excessive pressure build-up. Otherwise, the battery is completely sealed and is, therefore, maintenance-free, leak proof and usable in any position.



### Battery construction

Component	Positive plate	Negative plate	Container	Cover	Safety Valve	Terminal	Separator	Electrolyte
Raw material	Lead dioxide	Lead	ABS	ABS	Rubber	Copper	Fiberglass	Sulfuric acid

### General features

- Absorbent Glass Mat (AGM) technology for efficient gas recombination of up to 99% and freedom from electrolyte maintenance or water adding.
- Not restricted for air transport-complies with IATA/ICAO Special Provision A67.
- UL-recognized component.
- Can be mounted in any orientation.
- Computer designed lead, calcium tin alloy grid for high power density
- Long service life, float or cyclic applications.
- Maintenance-free operation.
- Low self discharge.

### Dimensions and weight

Length (mm / inch) ..... 151 / 5,94  
 Width (mm / inch) ..... 98 / 3,86  
 Height (mm / inch) ..... 95 / 3,75  
 Total Height (mm / inch) ..... 101 / 3,98  
 Approx Weight (Kg / lbs) ..... 3,67 / 8,10

Terminal Type : F2 (6,3MM)

### Performance characteristics

**NOMINAL VOLTAGE** ..... 12V  
**NUMBER OF CELL** ..... 6  
**NOMINAL CAPACITY (25°C)**  
 20 hour rate (0.60A - 10.5V) ..... 12.0Ah  
 10 hour rate (1.14A - 10.5V) ..... 11.4Ah  
 5 hour rate (2.07A - 10.2V) ..... 10.3Ah  
 1 hour rate (8.14A - 9.6V) ..... 8.14Ah  
**INTERNAL RESISTANCE**  
 Fully Charged battery (25°C) ..... 17 mOhms  
**SELF-DISCHARGE**  
 3% of capacity declined per month at 20°C (average)  
**OPERATING TEMPERATURE RANGE**  
 Discharge ..... -20 — 60°C  
 Charge ..... -10 — 60°C  
 Storage ..... -20 — 60°C  
**MAX DISCHARGE CURRENT**  
 77°F (25°C) ..... 180A (5s)  
**CHARGE METHODS** Constant Voltage Charge 77°C (25°C)  
**Cycle use** ..... 14,4 — 14,7V  
 Maximum charging current ..... 4.8A  
 Temperature compensation ..... -30mV/°C  
**Standby use** ..... 13,5 — 13,8V  
 Temperature compensation ..... -20mV/°C

### INTERNATIONAL STANDARD REFERENCES

- EN 60896-21
- EN 60896-22
- BS 6290-4
- EN 50272-2
- EUROBAT 3-5 years  
 "Standard commercial"

### CERTIFIED

- ISO 9001
- ISO 14001
- UL Component

### CASE BOX

Available in  
 Flame Retardant  
 UL94 V0 version

### Battery and terminal dimensions

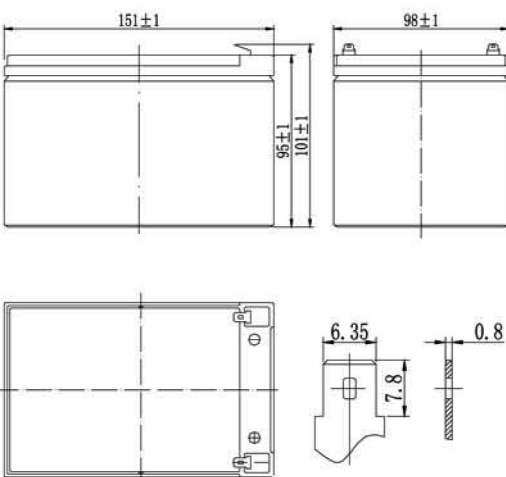

### Discharge constant current (Ampere at 77°F 25°C)

TIME	5 min	10 min	15 min	30 min	60 min	3 h	5 h	10 h	20 h
1.60 V	46,4	31,7	24,8	13,8	8,14	3,18	2,12	1,18	0,61
1.65 V	45,0	30,8	24,3	13,5	8,04	3,15	2,10	1,17	0,61
1.70 V	43,5	29,9	23,7	13,3	7,94	3,12	2,07	1,16	0,61
1.75 V	42,1	29,0	23,2	13,0	7,85	3,09	2,05	1,14	0,60
1.80 V	40,6	28,2	22,6	12,7	7,75	3,06	2,02	1,2	0,59

### Discharge constant power (Watts/cell at 77°F 25°C)

TIME	5 min	10 min	15 min	30 min	45 min	60 min	2 h	3 h	5 h
1.60 V	86,2	58,7	46,7	27,0	20,6	16,1	8,50	6,50	4,20
1.65 V	84,1	57,7	46,0	26,6	20,4	16,0	8,42	6,44	4,17
1.70 V	81,9	56,6	45,3	26,2	20,1	15,8	8,33	6,37	4,14
1.75 V	79,8	55,6	44,6	25,8	19,9	15,7	8,25	6,31	4,11
1.80 V	77,6	54,6	43,9	25,4	19,6	15,5	8,16	6,24	4,08