

Central Article Code: G31072A08-A  
ETN Code or Other: 31M700BXLW

Created: 08/06/2010  
Modified: 21/09/2010

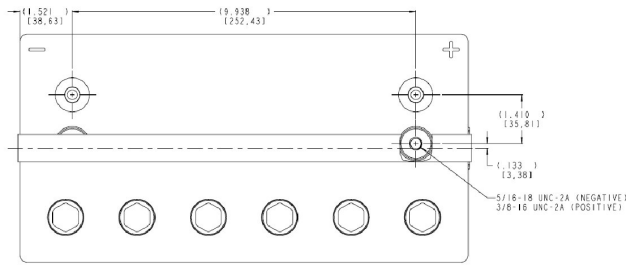

Final Outlook	G3108-A
Approval date	15/06/2010

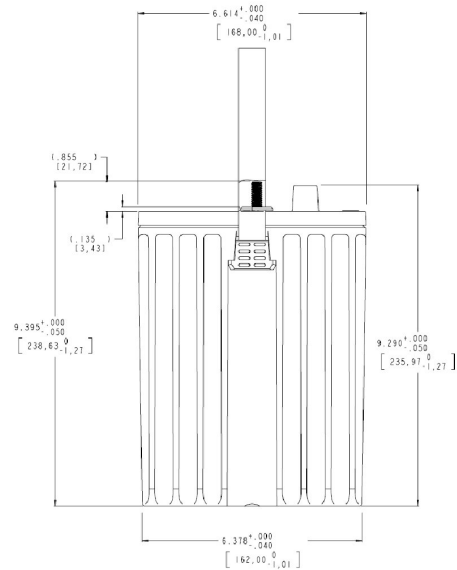
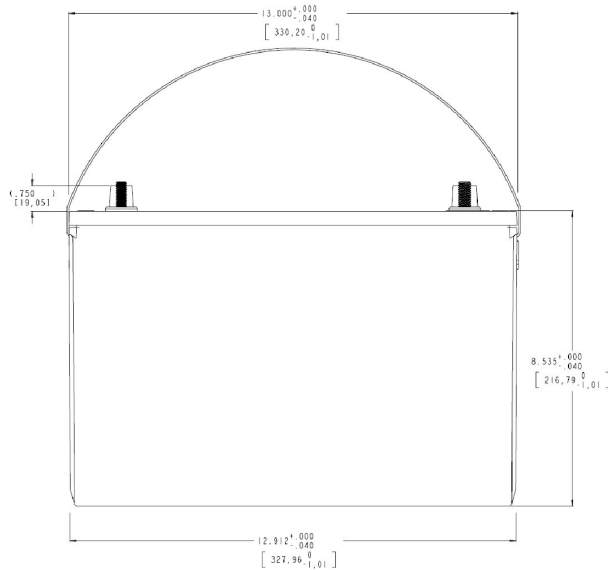

PERFORMANCES		CONTAINER	
Voltage (V):	12 V	Type:	G31 BLACK
C20 (Ah):	100.0 20 h	Hold Down:	B0
Rc (min):	200	H. D. Adapter:	No
Cranking (A):	720 EN	COVER	
Vibration:	V3 (35Hz/6g/20h)	Type:	Flat/Press BLUE LIGHT
Endurance:	500 cycles@75%	Polarity:	ETN 1
Charge:	CHARGED	Terminals:	SAE M 3/8"- 5/16" taper&stud
Technology:	AGM	Terminal Adapter:	No
Grid :	Ca/Ca	SOCI:	No
WEIGHT AND STD. DIMENSIONS		Ventilation:	Independent
Battery Weight (kg):	31.84	Filter:	No
Volume acid (l):	0.00	Lateral Plug:	No
Length (mm):	330	PLUGS	
Width (mm):	173	Type:	6 x M18 Valve GREY MEDIUM
Height (mm):	240	HANDLES	
		Type:	1 x Strip BLACK
		OTHERS	
		Degassing Tube:	No
		3/8-5/16 nuts in plastic bag	

All figures show nominal values. Tolerances are according to EN50342 and applicable European Regulations