

BATTERIA SIGILLATA AGM CON ELEVATO SPUNTO DI AVVIAMENTO  
 AGM MAINTENANCE FREE BATTERY WITH HIGH CRANKING RATE

# ZPC120100



## CHARACTERISTIC / CARATTERISTICHE

Volt		12V
Capacity / Capacità	20h	200Ah
Positive / Positivo		sx
EN Cranking features / Prestazioni avviamento EN	CCA	1250Amp
	CA	1500Amp
Self-Discharge 25°C Capacity / Autoscarica a 25°C	after 3 month storage	90%
	after 6 month storage	80%
	after 12 month storage	62%

## CHARACTERISTIC / CARATTERISTICHE

Battery dimensions / Dimensioni batteria			
L/L	W/P	H/A	Tot - H/A
530	206	210	248
Weight / Peso			57 Kg
Terminal / Terminali			AP
Plt Qt / Qt per pallet			18
Case / Contenitore			ABS

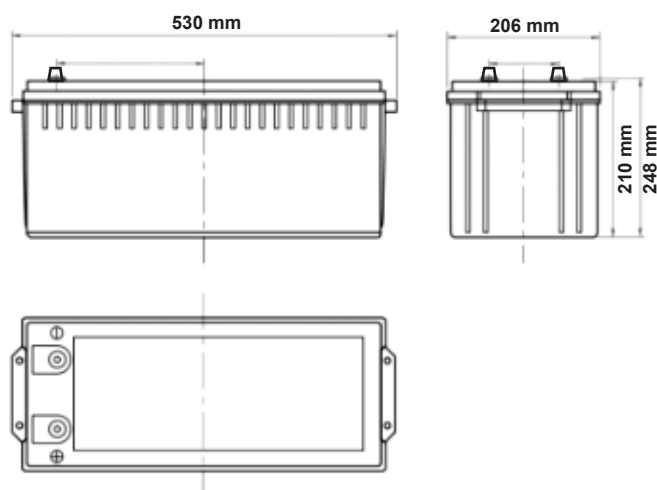

This information is generally descriptive only and is not intended to make or imply any representation, guarantee or warranty with respect to any cells and batteries. Cell and battery designs/specifications are subject to modification without notice. Contact U.B.S. UNION BATTERY SERVICE for the latest information.

Le informazioni contenute in questa scheda tecnica sono solo descrittive e indicative, non sono una garanzia. U.B.S. UNION BATTERY SERVICE si riserva il diritto di aggiornarle/modificarle senza preavviso.



[www.unionbatteryservice.it](http://www.unionbatteryservice.it)